



# 1

## INTRODUCTION

### LEARNING OBJECTIVES

After studying the chapter the students familiarize themselves with the following concepts:

- ◆ *Introducing the subject Microbiology and significance of microorganisms*
- ◆ *Different varieties of microscopes their invention and constructions along with simplified ray diagrams*
- ◆ *Contribution of scientists for the development of microbiology*
- ◆ *Introducing various Branches of Microbiology*

The term Microbiology is coined with 3 Greek words (*Mikro – small, bios - life, logos science*). In other words it is the study of organisms of microscopic size (microorganisms) including their culture, economic importance, pathogenicity, etc. This study is concerned with their form, structure, reproduction, physiology, metabolism and classification. It includes the changes which microorganisms bring about in other organisms and in nonliving matter and their distribution in nature, their effects on human beings and on other animals and plants, their abilities to make physical and chemical changes in our environment and their reactions to physical and chemical agents. This study revealed the fact that there are many a great number of very tiny life forms all about us everywhere too small to be seen usually by the naked eye. These organisms are usually invisible to naked eye because they are in micron size. Our eye fails to perceive any object that has a diameter less than 0.1 mm, so it is necessary to use microscope to see these tiny forms of life.

However, some microorganisms, particularly some eukaryotic microbes, are visible without microscopes. For example, bread molds and filamentous algae are studied by microbiologists, yet are visible to the naked eye, as are the two bacteria *Thiomargarita* and *Epulopiscium*.

The difficulty in setting the boundaries of microbiology has led to the suggestion of other criteria for defining the field. For instance, an important characteristic of microorganisms, even those that are large and multi cellular is that, they are relatively simple in their construction, lacking highly differentiated cells and distinct tissues.

Another definition for this field is based in terms of techniques employed such as sterilization and the use of culture media that are necessary for successful isolation and growth of microorganisms. Microorganisms include acellular entities (e.g., viruses), prokaryotic cells and eukaryotic cells. Cellular microorganisms are found in all three domains of life *Bacteria*, *Archaea* and *Eucarya*.

It is estimated that microbes contain 50% of the biological carbon and 90% of the biological nitrogen on earth. They greatly exceed every group of organisms on the planet in number.

### 1.1 Significance of Microorganisms

Microorganisms are found in all places from geothermal vents in the oceans depths to the coldest arctic ice, to every person's skin. They are major contributors to the functioning of the biosphere, being indispensable for the cycling of the elements essential for life. They also are a source of nutrients at the base of all ecological food chains and webs. Most importantly, certain microorganisms carryout photosynthesis, rivaling plants in their role of capturing Carbon dioxide and releasing oxygen into the atmosphere. Those microbes that inhabit humans also play important roles; including helping the body digests food and producing vitamins B and K. In addition society in general benefits from microorganisms, as they are necessary for the production of bread, cheese, beer, antibiotics, vaccines, vitamins, enzymes and many other important products. Indeed modern biotechnology rests upon a microbiological foundation.

Although majority of microorganisms play beneficial or benign roles, some harm humans and have disrupted society over the millennia. Microbial disease undoubtedly played a major role in historical events such as the decline of Roman Empire and the conquest of the new world. In 1347, plague or Black death, an arthropod – borne disease struck Europe with brutal force, killing 1/3 of the population (about 25 million people) within four years. Over the next 80 years, the disease struck again and again, eventually wiping out 75% of the European population. The plague's effect was so great that some historians believe, it changed European culture and prepared the way for the Renaissance. Today the struggle by microbiologists and others against killers like AIDS and malaria continue.

According to present knowledge we may put *Archaeobacteria*, *Bacteria*, *Cyanobacteria*, *Microalgae*, *Protozoans*, *Microfungi*, *Viruses*, *Viroids*, *Prions* etc., under the domain of microorganisms. Viruses are ultramicroscopic and have an obligate *parasitic* relationship but for particular purpose these still come under the domain of

microorganisms. Microorganisms (Bacteria) were undoubtedly the first living inhabitants on the earth and they were anaerobic as molecular oxygen was either absent or present only in trace amounts. The oldest fossil records of plants and animals are only 0.6–0.7 million years old, but now there is credible evidence that microbial life existed more than 3.5 billion years ago, that is, just 1 billion years after the formation of the earth and almost 3 billion years before plants and animals appeared on Earth.

### 1.1.1 Endosymbiosis

#### *Gr. endon "Within", Syn "Together" and Biosis "Living"*

- ◆ It is an evolutionary theory that explains the origin of eukaryotic cells from prokaryotes. It states that several key organelles of eukaryotes originated as a symbiosis between separate single-celled organisms. According to this theory, mitochondria, plastids (for example chloroplasts), and possibly other organelles representing formerly free-living bacteria, were taken inside by another cell as an endosymbiont around 1.5 billion years ago. Molecular and biochemical evidence suggest that mitochondria developed from proteobacteria (in particular, Rickettsiales, or close relatives) and chloroplasts from cyanobacteria (in particular, nitrogen-fixing filamentous cyanobacteria).
- ◆ Endosymbiosis is the name given to processes wherein one cell lives inside another cell in a mutualist fashion.
- ◆ They usually involve, a smaller prokaryotic cell living within the cytoplasm of eukaryotic cell.
- ◆ Endosymbiosis events between eukaryotic and prokaryotic cells have been taking place since the origin of the eukaryotic cell.
- ◆ About 1.5-2 billion years ago, oxygenic photosynthesis and aerobic respiration were predominant types of metabolism in bacteria.
- ◆ Cyanobacteria produced all of the earth's atmospheric (O<sub>2</sub>) and oxygen respiratory bacteria had developed. Sophisticated membrane system allowing them to reduce O<sub>2</sub> and generate relatively large amounts of energy.
- ◆ The eukaryotic cell could provide nutrients and a protected habitat for its invader or prey. The prokaryotes invaded by primitive eukaryotic cells, hence, the two organisms were able to enter into a mutually beneficial and stable relationship.
- ◆ Eukaryotic organelles contain their own genome (DNA) and ribosomes both of which have a bacterial configuration and function.

- ◆ They synthesize their own proteins, chloroplasts and have the same type of chlorophyll, enzymes and metabolism as respiratory bacteria such as “Pseudomonas” and other proteobacteria.
- ◆ Based on their nutrition patterns, morphology, molecular arrangements these are evolved into distinct types.

## 1.2 Structure of Eukaryotic and Prokaryotic Cells

- ◆ Prokaryotic organisms (Archaea and Bacteria) and eukaryotic organisms (both unicellular and multi cellular forms) have evolved as two distinctive types of cells, differing fundamentally in their cell structure.
- ◆ Eukaryotes always contain a membrane enclosed nucleus, multiple chromosomes and various other membranous organelles, such as mitochondria, chloroplast, golgi apparatus, vacuoles etc.
- ◆ Prokaryotic cells are typically much smaller in size and never contain a nuclear membrane around their genetic material.
- ◆ The fundamental differences between eukaryotic and prokaryotic cells, as well as the similarities and differences between eukaryotes, bacteria and archaea, are evidenced by their nuclear organization, their cell wall, cell membrane and ribosome structure and their modes of protein synthesis.

## 1.3 Evolution of Microorganisms on Earth

The earth was still in the process of developing and had a reduced atmosphere before life originated on it. It is thought that the reduced atmosphere of earth consisted largely of gaseous forms of nitrogen, hydrogen, carbon dioxide and water vapour, with smaller amounts of ammonia, carbon monoxide and hydrogen sulphide.

Oxygen was either absent or present only in trace amounts or therefore, the atmosphere was anaerobic (oxygen-free). Torrential rains poured over the developing Earth for centuries forming large masses of water in which the original gaseous raw materials of atmosphere gradually dissolved forming “ocean”.

The oceans were like a ‘broth’ and with the aid of energy from ultraviolet rays and electrical discharges (lightening), variety of organic compounds were synthesized progressively in them abiotic (nonliving) reactions and these organic compounds slowly evolved into larger and more complex organic molecules (macromolecules). The macromolecules had inherent tendency to aggregate in various combinations and appeared as distinct bodies (the microspheres) in the surrounding water medium.

These microspheres are postulated to be the first step toward cellular organization and referred to as progenotes or protobionts. Acquisition and use of nucleic acids, development of enzymatic capabilities and membrane organization further led the progenotes or protobionts to create eugenotes or primitive version of prokaryotic cell (bacterial cell).

The microorganisms are almost Omni present and are characterized with a very high degree of adaptability. They constitute a world of their own; full of uniqueness from different biological standpoints. The microbial world is spread over the entire biosphere- the lithosphere (rocky substances), the hydrosphere (liquid components) and the atmosphere (gaseous mantle envelopes the litho and hydrosphere); the latter being their temporary abode. The microorganisms are also found in the living as well as dead bodies of the organisms.

## 1.4 Microscopy

Microscope is the instrument used to provide magnification that enables us to see microorganisms and their structures which are invisible to the naked eye shown in Fig. 1.1.

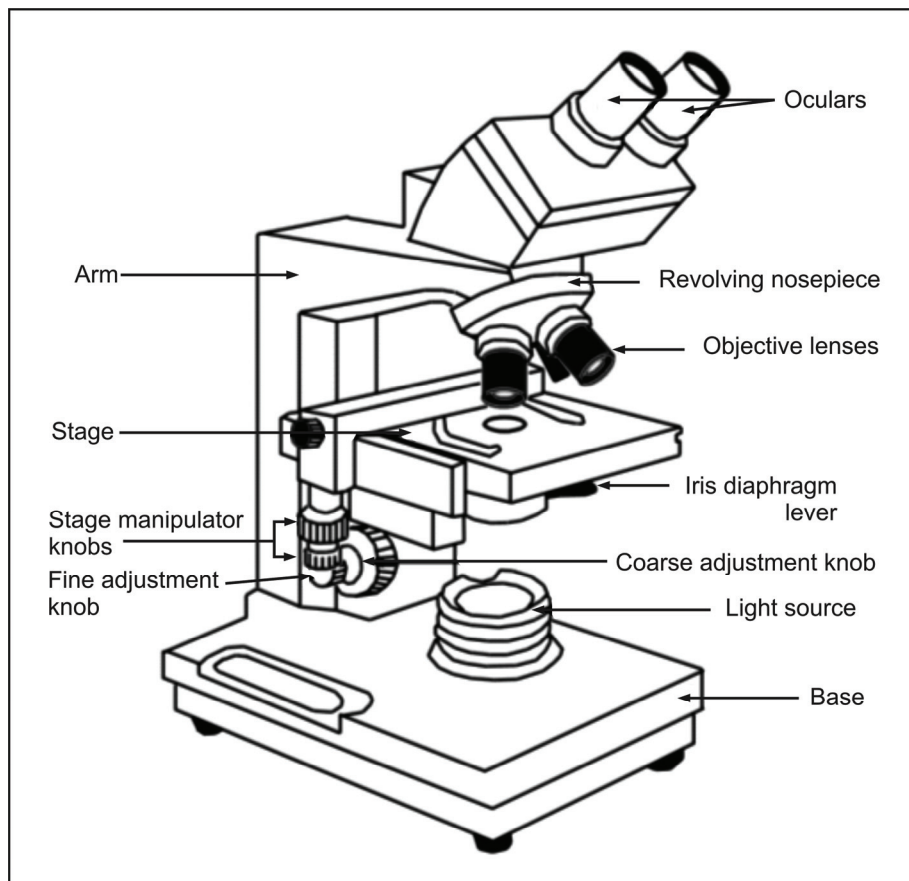

Fig. 1.1 Microscope

The magnification attained by microscopes range from 100 to 400,000.

*Microscopes are of two categories:*

1. Light or Optical microscopes
2. Electron microscopes

### 1.4.1 Light or Optical Microscopes

In this microscopes magnification is obtained by a system of optical lenses using light waves. These include:

1. Bright-field Microscope
2. Dark-field Microscope
3. Fluorescence Microscope
4. Phase-contrast Microscope

- 1. Bright-Field Microscope:** In this microscopy the microscopic field is brightly lighted and the microorganisms appear dark because they absorb some of the light. Ordinarily, microorganisms do not absorb much light, but staining them with a dye greatly increases their light-absorbing ability, resulting in greater contrast and color differentiation shown in Fig. 1.2.

These microscopes are useful in providing magnification of about  $1000 \times$  to  $1200 \times$ .

**Resolving power:** It is the ability of a microscope to distinguish two adjacent points as distinct and separate. The basic limitation of Bright-Field microscope is resolving power. The largest magnification produced by a microscope may not be useful because the image may be unclear and fuzzy.

The more lines or dots per unit area that can be seen distinctly as separate lines or dots, the greater the resolving power of microscope.

This resolving power of a microscope is a function of wavelength of light used and the numerical aperture (NA) of the lens system.

**Numerical Aperture (NA):** The angle  $O$  subtended by the optical axis and the outermost rays still covered by the objective is the measure of aperture of the objective. It is the half aperture angle.

The magnitude of this angle is expressed as a sine value. The sine value of the half-aperture angle multiplied by the refractive index "n" of the medium filling the space between front lens and the cover slip gives the numerical aperture (NA):  $NA = n \sin O$ . With dry objectives the value of "n" is 1, since refractive index ( $R_1$ ) of air is 1.

When oil immersion is used as the medium, n is 1.56 and if  $O = 58$  degrees, then  $NA = n \sin O = 1.56 \times 58 \text{ degree} = 1.56 \times 0.85 = 1.33$ .

**Limit of Resolution:** It is the smallest distance by which two objects can be separated.

The greatest resolution in light microscopy is obtained with shorter wavelength of visible light and an objective with the maximum Numerical Aperture.

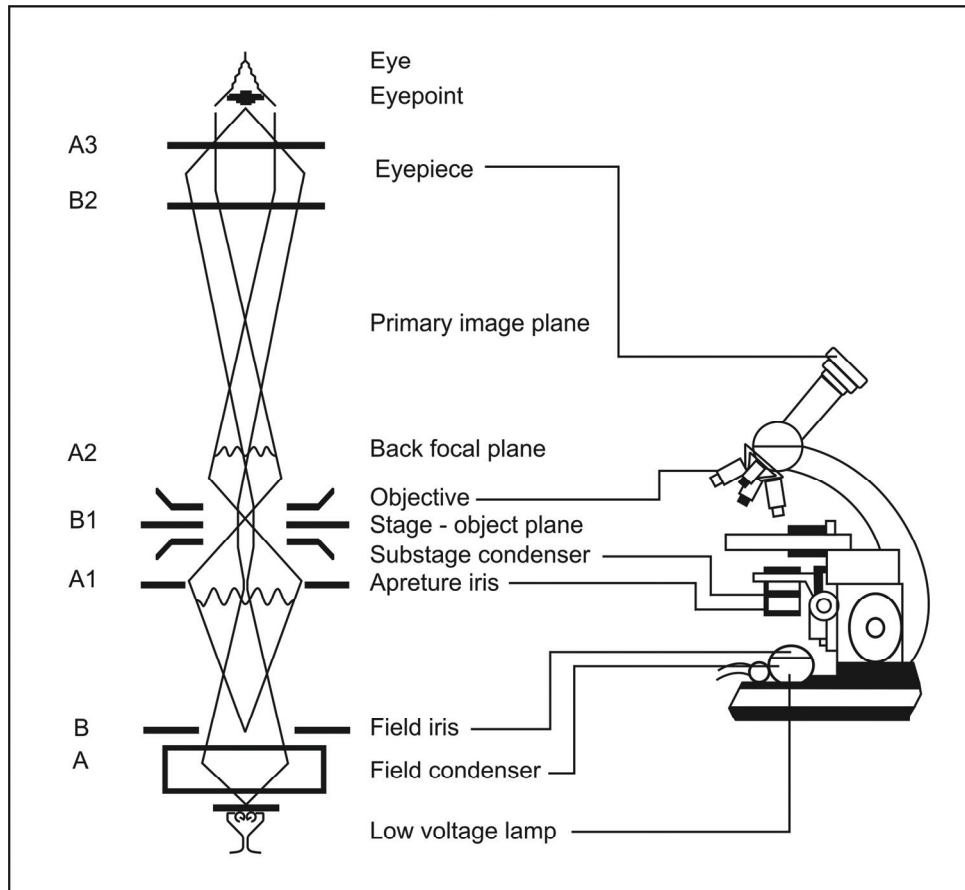

Fig. 1.2 Bright field microscope pathways

The relationship between NA and resolution can be expressed as

$$d = \lambda / 2NA$$

Where  $d$  = resolution,  $\lambda$  = wavelength.

**Magnification:** magnification beyond the resolving power is of no value since larger image will be less distinct and fuzzy in appearance.

Microscopes are equipped with 3 objectives each capable of a different degree of magnification and they are oil-immersion, high-dry and low-power objectives.

The total magnification is determined by multiplying the magnifying power of objective and that of the eye-piece.

An eye- piece of a magnification of 10 is used. Objectives used are 10x;40x and 100x (oil immersion objective).

**2. Dark-Field Microscopy:** The effect produced by this microscope is that of a dark background against which objects are brightly illuminated.

It contains equipment with a special kind of condenser that transmits a hollow cone of light from source of illumination.

Most of the light directed through the condenser does not enter the objective, so field is essentially dark. And some of the light rays will be scattered if transparent medium contains objects such as microbial cells shown in Fig. 1.3 and 1.4. This ray will enter the objective and reach the eye, thus the object will appear bright.

This microscopy is valuable for examining of unstained microorganisms suspended in fluid - wet - mount and hanging drop preparation.

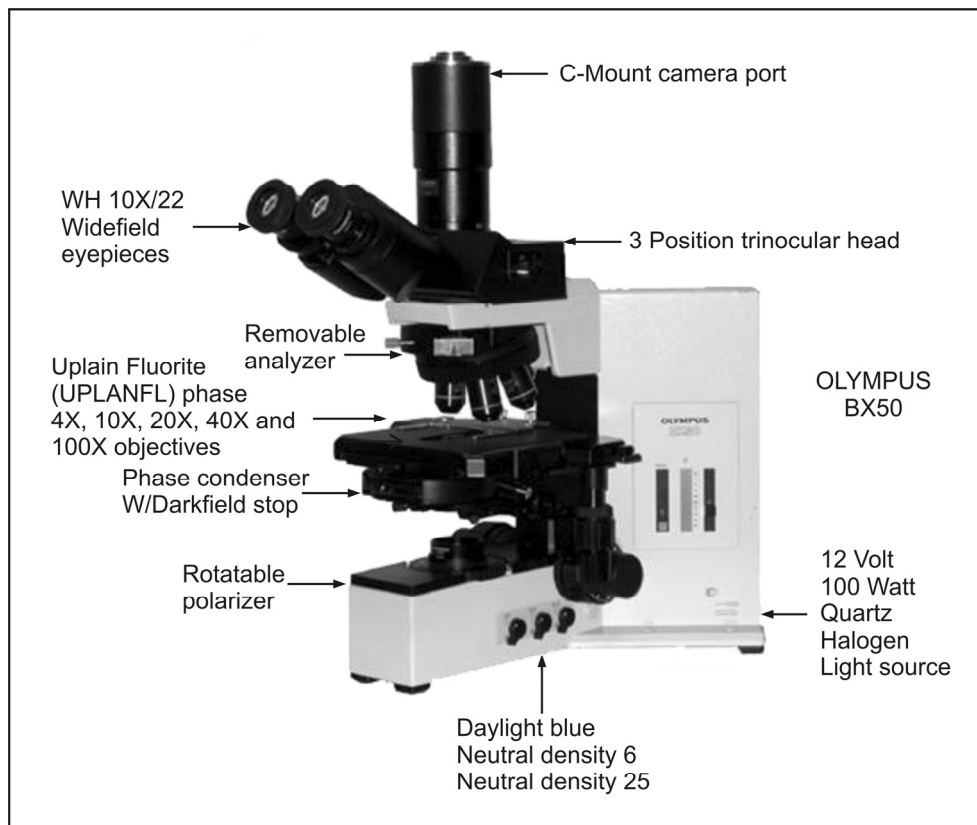
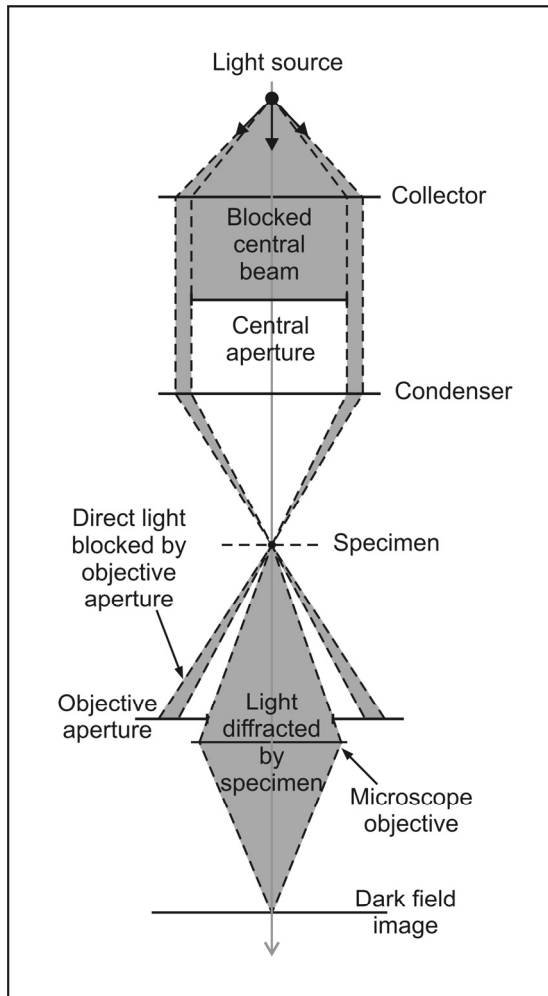

Fig. 1.3 Dark field microscopy





**Fig. 1.4** Light path through dark field microscope

**3. Fluorescence Microscope:** Many chemical substances absorb light of a particular wavelength and energy and some substances will emit light of longer wave length and less energy content. Such substances are called fluorescent and the phenomenon is termed as fluorescence. In this microorganisms are stained with a fluorescent dye and then illuminated with blue light, the blue light is absorbed and green light is emitted shown in Fig. 1.5.

The function of exciter-filter is to remove all but blue light. Barrier filter block out blue light and allows green light to pass through.

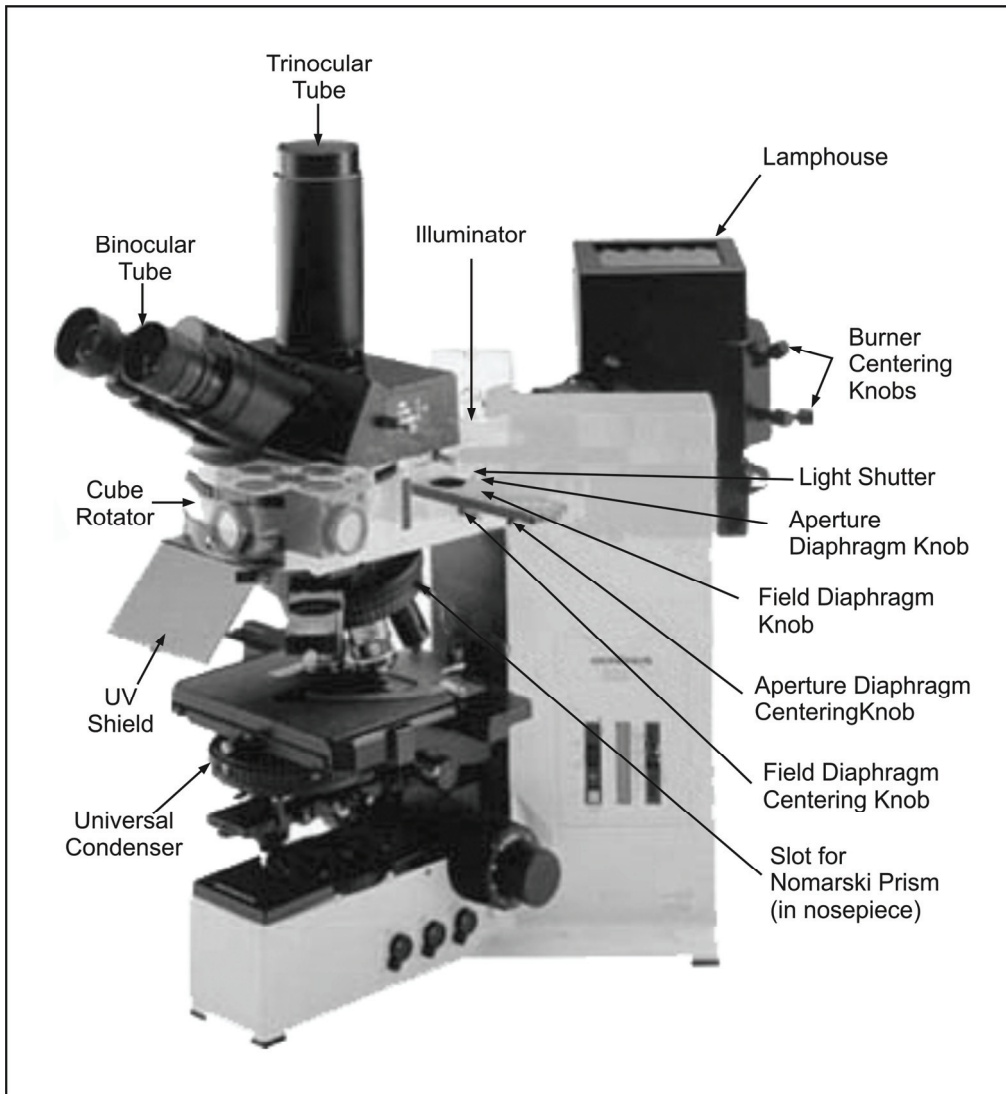

Fig. 1.5 Fluorescence microscope

**4. Phase-Contrast Microscopy:** The principle is based on the fact that light passing through one material and into another material of a slightly different refractive index and thickness will undergo a change in phase. These differences in phase are translated into variations in brightness of the structures and hence are detectable by the eye shown in Fig. 1.6, 1.7 and 1.8.

With phase-contrast microscopy it is possible to reveal differences in cell and their structures.

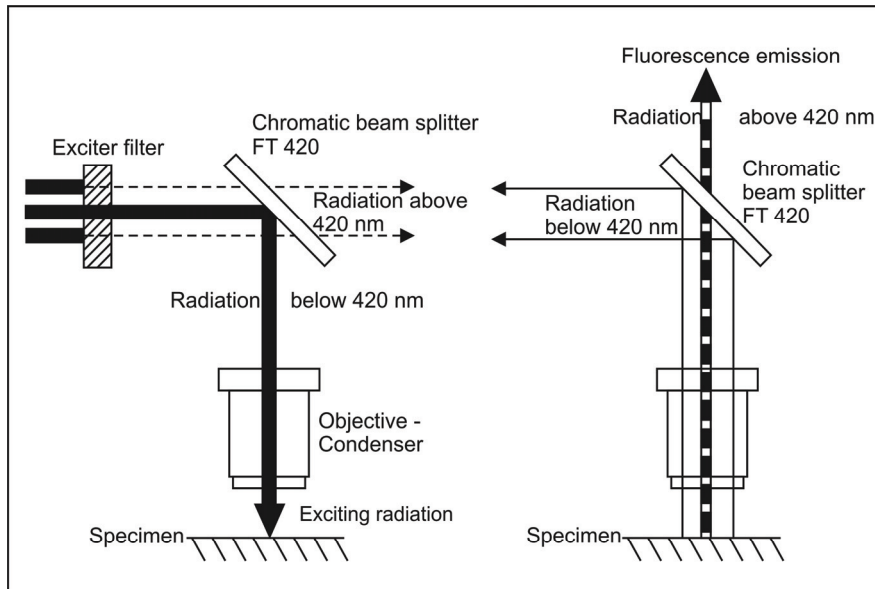

Fig. 1.6 Fluorescence microscope pathways

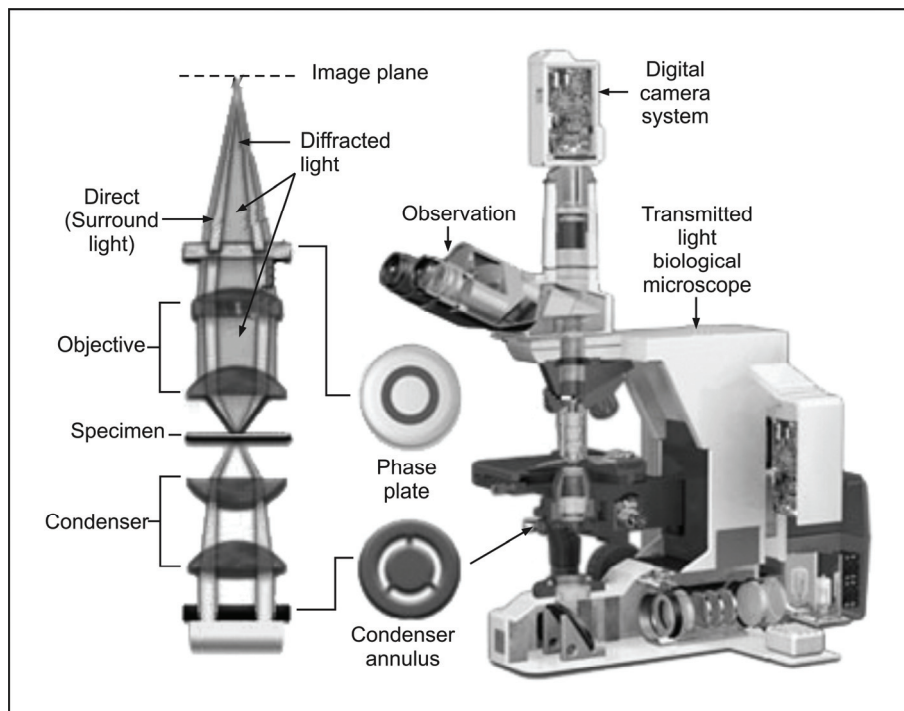
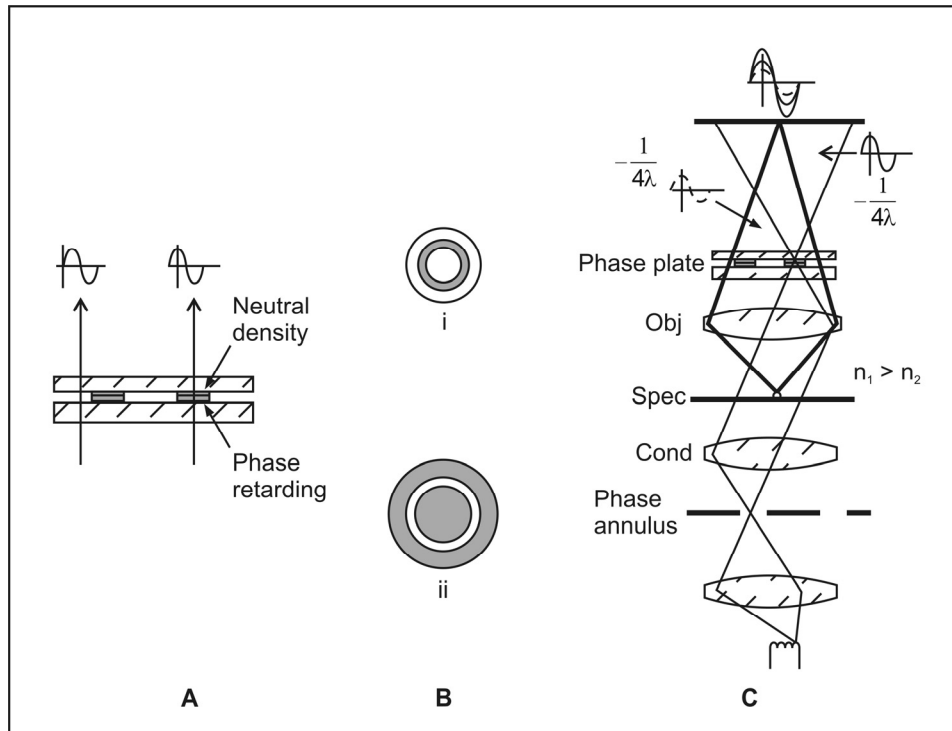

Fig. 1.7 Phase contrast microscope configuration



**Fig. 1.8** Zernike negative phase contrast. **A:** Construction of the phase plate showing the relative phase shifts induced by the phase rings. **B:** Face view of the phase annulus (ii) and phase plate (i) **C:** The optical path for phase contrast illumination. Cond: condenser lens; Spec: specimen plane; Obj: objective lens;  $n_1, n_2$ : refractive index of the sample and background, respectively, (Figure C redrawn from Francon, 1968.)

## 1.4.2 Electron Microscope

It uses a beam of electron in place of light waves to produce the image, Specimens can be examined by either transmission electron microscopy or scanning electron microscopy.

### Transmission Electron Microscopy (TEM)

TEM (Fig. 1.9) was developed in 1931 by Max Knoll and Ernst Ruska at Berlin. It gives 2-D image and having resolution of 0.5 angstroms and gives up to 50 million magnification level. This microscope provides tremendous useful magnification, because of much higher resolution obtained with extremely short wave length. The electron microscope uses electron beams and magnetic fields to produce the image. Electrons replace light as the illuminating beam. They can be focused, much as light in a light

wavelength is around 0.005 nm, approximately 100,000 times shorter than that of visible light. Therefore electron microscope have a practical resolution roughly, 1,000 times better than the light microscope; with many electron microscopes, points closer than 0.5 nm can be distinguished, and the useful magnification is well over 100,000x.

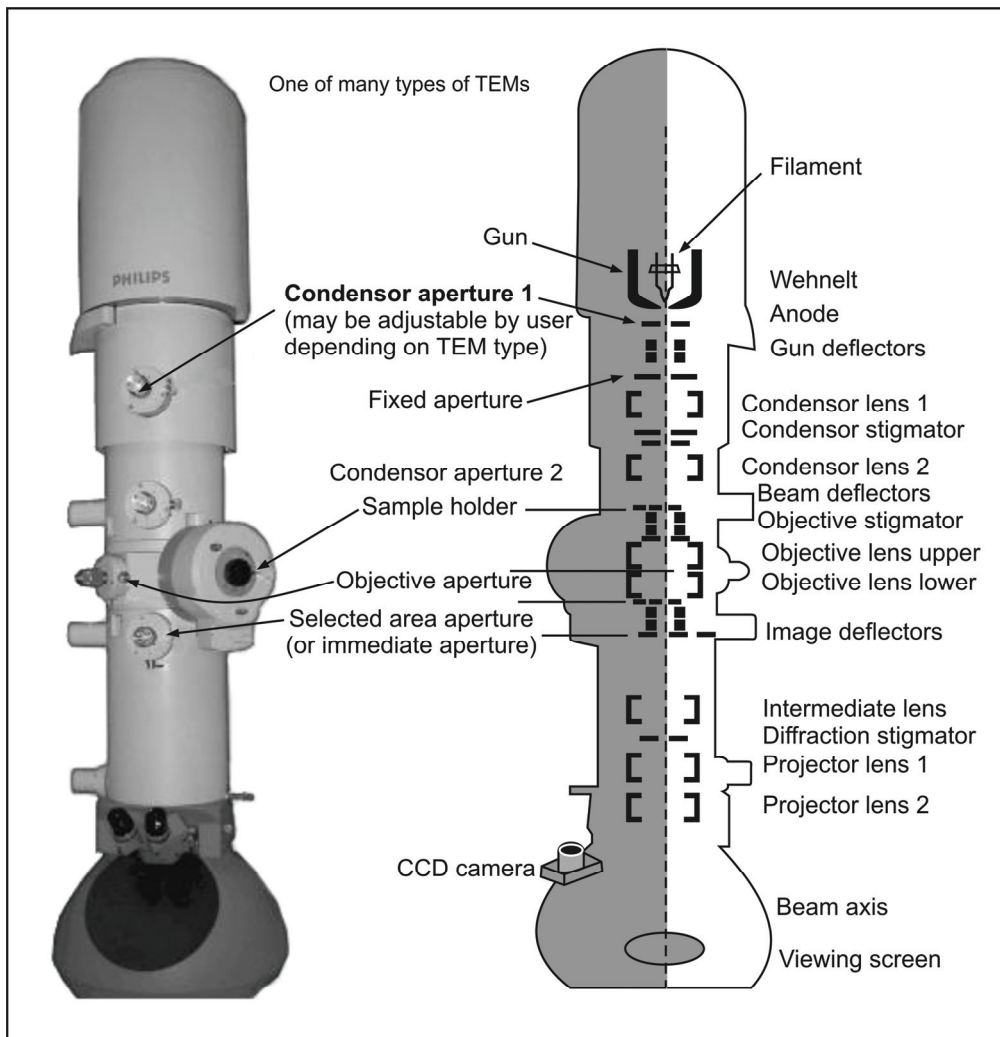

Fig. 1.9 Transmission electron microscopy (TEM)

**Working:** A modern transmission electron microscope (TEM) shown in Fig 1.9 is complex and sophisticated, but the basic principles behind its operation can be readily understood. A heated tungsten filament in the electron gun generates a beam of electrons that is then focused on the specimen by the condenser. Since electrons cannot pass through a glass lens, doughnut shaped electromagnets called magnetic lenses and specimen must be under high vacuum to obtain a clear image because electrons are deflected by collisions with air molecules. For this microscope, the specimen to be examined is prepared as an extremely thin dry film on small screens and is introduced into the instrument at a point between the magnetic condenser and the magnetic objective. The specimen scatters some electrons, but those that pass through are used to form an enlarged image of the specimen on a fluorescent screen. A denser region in the specimen scatters more electrons and therefore appears darker in the image since fewer electrons strike that area of the screen; these regions are said to be “electron dense”. In contrast, electron-transparent regions are brighter. The image can also be captured on photographic film as a permanent record. Extremely thin slices (20 to 100 nm) of a microbial specimen can be viewed in the average TEM.

***Steps in Transmission Electron Microscopy:***

1. Fixing the specimen with chemicals like glutaraldehyde or Orosmium tetra oxide to stabilize cell structure.
2. The specimen is dehydrated with organic solvents (acetone or ethanol).
3. The specimen is soaked in unpolymerized, liquid epoxy plastic until it is completely permeated,
4. The plastic is hardened to form a solid block.
5. Thin sections are cut from this block with a glass or diamond knife using a special instrument called an ultra microtone.
6. Specimens are prepared for observation by soaking thin sections with solutions of heavy metal salts like lead citrate and uranyl acetate (these ions bind to cell structures and make them more electron opaque, thus increases contrast in the material).
7. The stained thin sections are then mounted on tiny copper grids and viewed.

***Negative staining technique:*** Specimen is spread out in a thin film with either phosphor tungstic acid or uranyl acetate, (these do not penetrate the specimen but render the background, whereas the specimen appears bright in photographs).

***Uses:*** To study the structure of viruses, bacterial gas vacuoles and other similar objects.

**Shadowing:** A specimen is coated with a thin film of platinum or other heavy metal by evaporation at an angle of about 45 degrees from horizontal so that the metal strikes the microorganism on only one side.

The area coated with metal appears dark in photographs, whereas the uncoated side and the shadow region created by the object is light.

**Uses:** Useful in studying virus morphology, prokaryotic flagella and DNA.

### ***Freeze–Etching Electron Microscopy Method***

The introduction of the Balzers freeze-fracture machine by Hans Moor in 1961 had a much greater impact on the advancement of electron microscopy. Freeze-fracturing proved to be crucial for developing modern concepts of how biological membranes are organized, with this method within millisecond time-scale membrane dynamics can be captured. When freeze-fracturing was combined with methods for freezing cells that allowed microscopists to avoid even the aldehyde-prefixation and cryoprotection steps.

It is devised originally to find the solution

For the dangers of dehydration

For plastic embedding required for classical thin-section techniques

To provide unique en face views of cell membranes that could not be obtained by classical thin section techniques,

1. Cells are rapidly frozen in liquid nitrogen
2. Warmed to -100 degrees °C in a vacuum chamber.
3. A knife that has been pre cooled with liquid nitrogen fractures the frozen cells
4. Specimen is left in the high vacuum for a minute or more
5. The exposed surfaces shadowed and coated with layers of platinum and carbon to form a replica of the surface.
6. After the specimen has been removed chemically, this replica is studied in the TEM.

**Uses:** This provides three -dimensional view of intracellular structures. It minimizes the danger of artifacts.

### **Scanning Electron Microscope (SEM)**

In 1942, the first scanning electron microscope with a sub-micron probe was developed by Von Ardenne, a private consultant who had his own laboratory in Berlin, over the very short period of about 2 years. It gives 3-D image having up to 2 million magnification levels and 0.4 nanometers resolution.

In this microscopy, the specimen is subjected to a narrow electron beam which rapidly moves over the surface of the specimen, as a result causes the release of shower of secondary electrons and other types of radiation from the specimen surface. The SEM has

been used to examine the surfaces of microorganisms in great detail, many SEMs will have a resolution of 7 nm or less.

The secondary electrons are trapped by a special detector shown in Fig. 1.10 and 1.11. Secondary electrons entering the detector strike a scintillator causing it to emit light flashes that a photomultiplier converts to an electrical current and amplifies. These signals are scanned in a manner of a television system to produce an image on a cathode ray tube. It has the advantage of revealing a striking 3-dimensional picture. The surface topography of a specimen can be revealed with a clarity and depth of field not possible by any method. The disadvantage is that it lacks the resolving power.

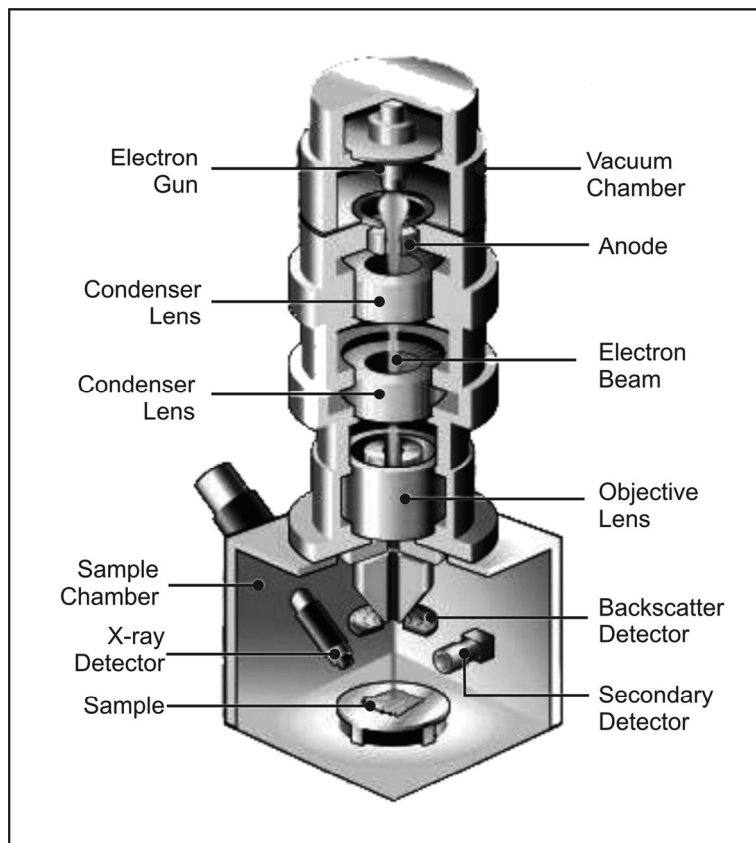

**Fig. 1.10** How scanning electron microscopes work



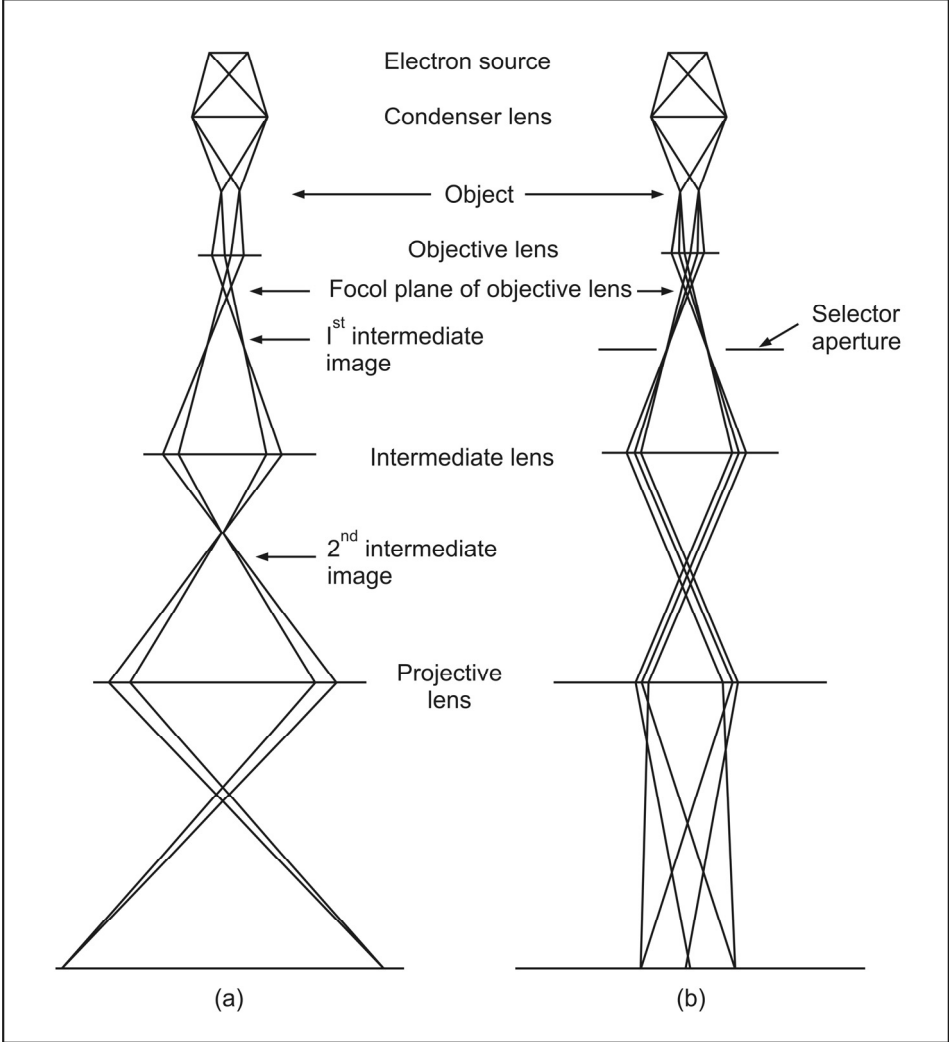
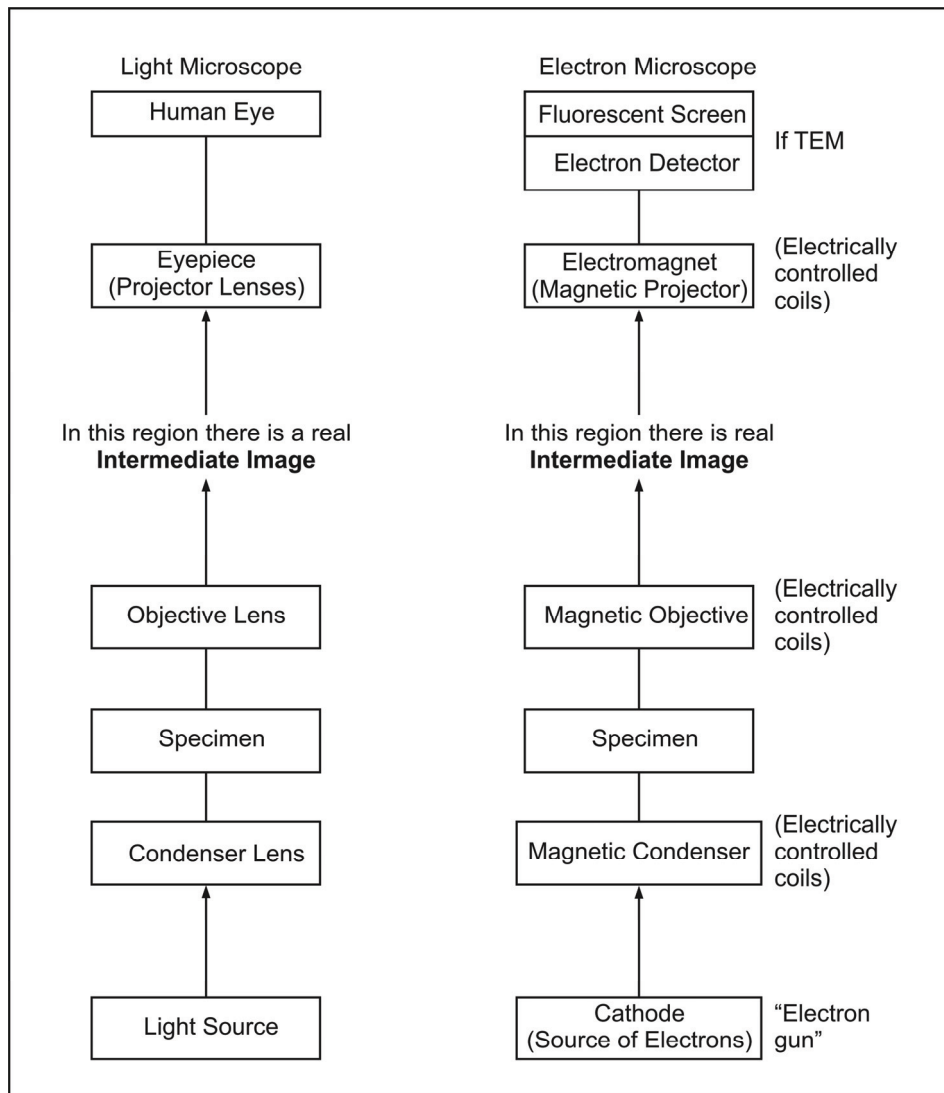

Fig. 1.11 The Electron Microscope (a) Cometrical optics representation of the TEM in imaging mode and (b) diffraction mode.

**Very simple Block Diagram of Electron vs Light Microscope**



**1.5 Contribution of Scientists**

**1.5.1 Antony Van Leeuwenhoek (1632-1723)**

Leeuwenhoek succeeded in making some of the most important discoveries in the history of biology. He set himself up in business as a draper (a fabric merchant), a wine assayer.

At sometime before 1668, Leeuwenhoek learned to grind lenses, made simple microscopes and began observing with them. He seems to have been inspired to take up microscopy by having seen a copy of Robert Hooke's illustrated book *Micrographia*, which depicted Hooke's own observations with the microscope and was a very popular.

Leeuwenhoek is known to have made over 500 "microscopes" of which fewer than ten have survived to the present day. In basic design, – were simply powerful magnifying glasses, not compound microscopes of the type used today.



Antony Van Leeuwenhoek

### Construction of Microscope (Fig. 1.12)

It is a simple device, using only one lens, mounted in a tiny hole in the brass plate that makes up the body of the instrument. The specimen was mounted on the sharp point that sticks up in front of the lens and its position and focus could be adjusted by turning the two screws. The entire instrument was only 3-4 inches long and had to be held up close to the eye; it required good lighting and great patience to use.

Compound microscopes (i.e., microscopes using more than one lens) had been invented by Robert Hooke (England) and Jan Swammerdam (Netherland) around 1595, nearly forty years before Leeuwenhoek was born. These were much more similar to the microscopes in use today. However, because of various technical difficulties in building them, early compound microscopes were not practical for magnifying objects more than about 20 or 30 times natural size.



Fig. 1.12 Microscope

Leeuwenhoek's skill at grinding lenses, together with his naturally acute eyesight and great care in adjusting the lighting where he worked, enabled him to build microscopes that magnified over 200 times, with clearer and brighter images than any of his colleagues could achieve. He was curious to observe almost anything that could be placed under his lenses and his care in describing what he saw which were instantly recognizable.

In 1673, Leeuwenhoek began writing letters to the newly – formed Royal Society of London, describing what he had seen with his microscopes –

His first letter contained some observations on the stings of bees.

For the next fifty years he corresponded with the Royal Society; his letters, written in Dutch, were translated into English or Latin and printed in the *Philosophical Transactions* of the Royal Society and often reprinted separately.

He described observations on lake water, including green chlorophyte algae *Spirogyra*. He gave descriptions of many protists, including this ciliate, *Vorticella*.

He wrote about his observations on the plaque between his own teeth. Leeuwenhoek found an unbelievably great company of living animalcules.

He looked at animal and plant tissues, at mineral crystals and at fossils. He was the first to see microscopic foraminifera, which described as “little cockles – no bigger than coarse sand–grain.”

He discovered blood cells and was the first to see living sperm cells of animals.

He discovered microscopic animals such as nematodes and rotifers.

In 1680 he was elected a full member of the Royal Society, joining other luminaries of his day – although he never attended a meeting.

In 1698 he demonstrated circulation in the capillaries of an eel; He continued his observations until the last days of his life finally he breathed his last on August 30<sup>th</sup> 1723.

Leeuwenhoek who was famous throughout the whole philosophical world was praised as remarkably good scientist and craftsman who worked with diligence and tireless to discover many secrets of Nature.

### 1.5.2 Alexander Fleming (6 August 1881-11 March 1955)

He was a Scottish biologist and pharmacologist. Fleming published many articles on bacteriology, immunology and chemotherapy. His best known achievements are the discovery of the enzyme lysozyme in 1923 and the antibiotic substance penicillin from the fungus *Penicillium notatum* in 1928, for which he shared Noble prize in physiology or Medicine in 1945 with H.W. Florey and E.B. Chain.

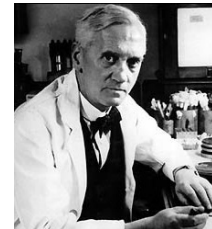

Fleming was born on 6 August 1881 Scotland. After his schooling, Fleming enrolled at St Mary’s Hospital, Paddington, London. He qualified for the school with distinction in 1906 and had the option of becoming surgeon. Fleming joined research department at St. Mary’s where he became assistant bacteriologist to Sir Almroth Wright, a pioneer in vaccine therapy and immunology. He gained M.B. and then B.Sc. with Gold Medal in 1908 and became a lecturer at St. Mary’s teaching hospital until 1914. He worked in battle field hospitals at the Western Front in France. In 1918 he returned to St. Mary’s Hospital, and was elected a Professor of Bacteriology in 1928.

After the war, Fleming actively searched for anti-bacterial agents, having witnessed the death of many soldiers from septicemia resulting from infected wounds. Unfortunately antiseptics killed the patients’ immunological defenses more effectively than they killed the invading bacteria because they were effective on the surface only.

By 1928, Fleming was investigating the properties of *staphylococci*. He was already well-known from his earlier work and had developed a reputation as a brilliant researcher. After returning from a long holiday, Fleming noticed that many of his culture dishes were contaminated with fungus and he threw the dishes in disinfectant. But subsequently, he had to show a visitor what he had been researching and so he retrieved some of the submerged dishes that he would have otherwise discarded. He then noticed a zone around an invading fungus where the bacteria could not seem to grow. Fleming proceeded to isolate an extract from the mold, correctly identified it as being from the *Penicillium* genus, and therefore named the agent penicillin.

He investigated its positive anti-bacterial effect on many organisms and noticed that it affected bacteria such as *staphylococci* and indeed all Gram-positive pathogens (scarlet fever, pneumonia, meningitis, diphtheria causing bacteria). It also affected gonorrhea, causing microbes, although this condition is caused by Gram-negative pathogen.

Fleming found cultivating *penicillium* was quite difficult, it was even more difficult to isolate the antibiotic agent and its action appeared to be rather slow. Fleming also became convinced that penicillin would not last long enough in the human body to kill bacteria effectively.

So Fleming soon abandoned penicillin and not long after Florey and Chain took up researching and mass producing it with funds from the U.S. and British governments. The mass production and mass distribution was done in 1945 after several clinical trials. Fleming was the first to discover the properties of the active substance. He also kept, grew and distributed the original mold for twelve years, and continued until 1940 to try to get help from any chemist that had enough skill to make penicillin.

Fleming's accidental discovery and isolation of penicillin in September 1928 marks the start of modern antibiotics. Fleming also discovered very early that bacteria develop antibiotic resistance whenever too little penicillin was used or when it was used for too short a period.

### 1.5.3 Louis Pasteur (December 27, 1822 – September 28, 1895)

He was a French chemist and microbiologist best known for his remarkable breakthroughs in the causes and prevention of disease. His experiments supported the germ theory of disease, also reducing mortality from puerperal fever (childbed) and he created the first vaccine for rabies. He was best known to general public for inventing a method to stop milk and wine from causing sickness – this process came to be *Pasteurization*. He is regarded as one of the three main founders of microbiology, together Ferdinand Cohn and Robert Koch. He also made many discoveries in the field of chemistry, most notably the asymmetry of crystals.



Louis Pasteur was born on December 27, 1822 in Dole in France and grew up in the town of Arbios. There he later has his house and laboratory, which is a Pasteur museum today. After serving briefly as professor of physics at Dijon Lycee in 1848, he became professor of chemistry at University of Strasbourg.

Pasteur found the concept of light rotation in crystals: in solution one form rotated light to the left, the other to the right, while an equal mixture of the two forms cancelled each other's rotation. Hence the mixture does not rotate polarized light.

He resolved a problem concerning the nature of tartaric acid. For the first time he demonstrated chiral molecule.

### **Spontaneous Generation (Abiogenesis) versus Biogenesis**

Pasteur performed experiments to demonstrate that the growth of microorganisms in nutrient broths is not due to spontaneous generation but rather to biogenesis. Pasteur showed that growth did not occur in infusions which had been heated but exposed to air provided the incoming air was treated to remove the microorganisms.

### **Fermentation**

Pasteur demonstrated that the fermentation process is caused by the growth of microorganisms. He found that fermentation of fruits and grains', resulting in alcohol, was brought by microbes. By proper selection of the microbe, the manufacturer might be assured of a consistently good and uniform product. Pasteur suggested that the undesirable types of microbes might be removed by heating - not enough to hurt the flavor of the fruit juice, but enough to destroy very high percentage of the microbial population. He found that holding the juices at a temperature of 62.8 °C (145 °F) for 30 minutes did the job pasteurization. Today Pasteurization is widely used in fermentation industries, but we are most familiar with it in the dairy industry.

### **Germ Theory of Disease**

Microorganisms are the causative agents of some diseases; many observant students had expressed strong arguments for the germ theory of disease. Fracastro, Von Plenciz, Jonathan Swift and Oliver Wendell Holmes are some of them. Pasteur's success in solving the problem of fermentation led the French government to request that he investigate perbine, a silkworm disease that was ruining an important French industry. For several years Pasteur struggled with this problem. Eventually he isolated the parasite (protozoan) causing the disease. He also showed that silkworm farmers could eliminate the disease by using only healthy, disease-free caterpillars for breeding stock. Pasteur next tackled the problem of anthrax, a disease of cattle, sheep, and sometimes human beings. He grew the microbes in laboratory flasks after isolating them from the blood of animals that had died of the disease. Robert Koch, German physician also identified *anthrax bacilli* in the blood of cattle that had died of anthrax. Koch's series of observations led to the establishment of Koch's postulates.

### **Immunology and Vaccination**

Pasteur continued to make discoveries concerning the cause and prevention of infectious diseases. About 1880 he isolated the bacterium responsible for chicken cholera and grew it in pure culture. Pasteur made use of the Robert Koch's postulates in this work.

**Experiment:** To prove that he really had isolated the organisms responsible for chicken cholera; he inoculated healthy chickens with his pure culture. But to his dismay, the chickens failed to get sick and die! Reviewing each step of the experiment, Pasteur found that he had accidentally used cultures several weeks old instead of the fresh ones grown especially for the demonstration. Some weeks later he repeated the experiment, using two groups of chickens. One of these groups had been inoculated at the first demonstration with the old cultures that had proved ineffective, and the second had not been previously, exposed. Both groups received bacteria from fresh young cultures.

### **Result**

Chickens in the second group (which were not previously exposed to old culture) got sick and died.

Chickens in the first group (which were previously exposed to old culture) remained hale and healthy

### **Explanation**

In some way bacteria could lose their ability to produce disease, i.e., their virulence, after standing and growing old.

But these attenuated (having decreased virulence) bacteria still retained their capacity for stimulating the host to produce substances, i.e., antibodies, that protect against subsequent exposure to virulent organisms.

This experiment of Pasteur explained the principle involved in Edward Jenner's successful use of cowpox virus, in 1798, to immunize people against smallpox.

Pasteur next applied this principle to the prevention of anthrax and again it worked.

He called the attenuated cultures vaccines, a term derived from the Latin *vacca*, meaning "cow" to honor Jenner who for the first time used cowpox material to immunize against smallpox

Pasteur produced the first vaccine for rabies by inoculating rabbits with saliva from mad dogs. Then the brain and spinal cord could be removed from the infected rabbits, dried for several days, pulverized and mixed with glycerin. Injecting this mixture into dogs protected them against rabies. Emile Roux a French doctor and a colleague of Pasteur helped Pasteur to prepare rabies vaccine. This vaccine was first used on 9 year old boy Joseph Meister on July 6, 1885, after the boy was badly mauled by a rabid dog. After consulting with colleagues, Pasteur decided to go ahead with the treatment. Pasteur was as surprised as anyone else when after the crucial trial, which took several weeks, Joseph Meister did not die.

#### 1.5.4 Robert Koch (11 December 1843 – 27 May 1910)

He was a German physician. He became famous for isolating anthrax causing *Bacillus anthracis*, the tuberculosis causing *Mycobacterium tuberculosis* and Cholera causing *Vibrio cholera* and for his series of observations led to the establishment of Koch's Postulates. He was awarded the Noble Prize in physiology or Medicine for his tuberculosis findings in 1905. He is considered one of the founders of microbiology.

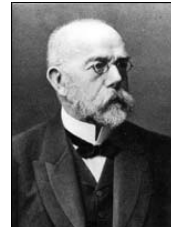

Heinrich Hermann Robert Koch was born in Clusthal, Germany as the son of a mining official. He studied medicine at the University of Göttingen and graduated in 1866. He then served in the Franco-Prussian War and later became district medical officer in Wollstein, working with very limited resources.

After Casimir Davaine showed the direct transmission of the *anthrax bacillus* between cows, Koch studied anthrax more closely; He invented methods to purify the bacillus from blood samples and grew pure cultures. He found that, while it could not survive outside a host for long, anthrax built persisting endospores that could last a long time.

These endospores, embedded in soil, were the cause of unexplained “spontaneous” outbreaks of anthrax. In 1881, he urged the sterilization of surgical instruments using heat.

In Berlin, he improved the methods he used in Wollstein, including staining and purification techniques and bacterial growth media, including agar plates i.e. Petri dishes (invented by Julius Richard Petri an assistant of Koch). Angelina wife of Walther Hesse student of Koch, suggested using agar as solidifying agent. These devices are still used today. With these techniques he was able to discover the bacterium causing tuberculosis in 1882.

In 1883, Koch worked with a French research team in Alexandria, Egypt, studying cholera. Koch identified the vibrio bacterium that caused cholera, though he never managed to prove it in experiments. The bacterium had been previously isolated by Italian anatomist Filippo Pacini in 1854, but his work had been ignored due to the predominance of the miasma (stinking miasma in the air) theory of disease. Koch was unaware of Pacini's work and made an independent discovery and his greater preeminence allowed the discovery to be widely spread for the benefit of others. In 1965, however, the bacterium was formerly renamed *Vibrio cholera Pacini* 1854. The series of observations led to the establishment of Koch's postulates, which provided guidelines to identify the causative agent of an infectious disease.

##### **Koch's postulates are**

1. A specific organism can always be found in association with a given disease.
2. The organism can be isolated and grown in pure culture in the laboratory.
3. The pure culture will produce the disease when inoculated into a susceptible animal.
4. It is possible to recover the organism in pure culture form the experimentally infected animal.



### 1.5.5 Joseph Lister (5 April 1827 – 10 February 1912)

He was an English surgeon who promoted the idea of sterile surgery while working at the Glasgow Royal Infirmary. He successfully introduced carbolic acid (phenol) to sterilize surgical instruments and to clean wounds.

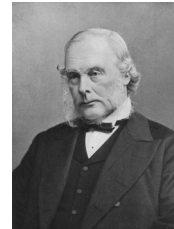

Joseph Lister came from a prosperous family, son of Joseph Jackson Lister, the pioneer of the compound microscope. He graduated with honours as Bachelor of Medicine and entered the Royal College of Surgeons. In 1867 Joseph discovered the use of carbolic acid as an antiseptic, such that it became the first widely used antiseptic in surgery. At University of Glasgow he was studying wound infection, at the time the usual explanation for wound infection was that the exposed tissues were damaged by chemicals in the air or via a stinking “miasma” in the air. The sick wards actually smelled bad, not due to a “miasma” but due to the rotting of wounds. Hospital wards were occasionally aired out at midday, but Florence Nightingale’s doctrine of fresh air was still seen as science fiction. Facilities for washing hands or the patient’s wounds did not exist and it was even considered unnecessary for the surgeon to wash his hands before he saw a patient.

Lister became aware of a paper published (in French) by Louis Pasteur that rotting and fermentation could occur without any oxygen if microorganisms were present. Lister confirmed this with his own experiments. If microorganisms were causing gangrene, the problem was how to get rid of them. Pasteur suggested three methods: filter, heat, or expose them to chemical solutions. The first two were inappropriate in a human wound, so Lister experimented with the third.

Carbolic acid (phenol) had been in use as a means of deodorizing sewage, so Lister tested the results of spraying instruments, the surgical incisions and dressings with a solution of it. Lister found that carbolic acid solution swabbed on wounds markedly reduced the incidence of gangrene and subsequently published a series of articles in 1867.

He also made surgeons wear clean gloves and wash their hand before and after operations with 5% carbolic acid solutions. Instruments were also washed in the same solution and assistants sprayed the solution in the operating theatre. One of his conclusions was to stop using porous natural material in manufacturing the handles of medical instruments.

Lister in 1869, returning to Edinburgh continued to develop improved methods of antiseptics and asepsis.

As germ theory of disease became more widely accepted, it was realized that infection could be better avoided by preventing bacteria from getting into wounds in the first place. This led to the rise of sterile surgery. Some consider Lister “the father of modern antiseptics.”

In 1879 Listerine mouthwash was named after him for his work in antiseptics. Also named in his honour is the bacterial genus *Listeria*, typified by the food-borne pathogen *Listeria monocytogenes*.

Lister in King's College Hospital in London, became the second man in England to operate on a brain tumor. He also developed a method of repairing kneecaps with metal wire and improved the technique of mastectomy. His discoveries were greatly praised.

### 1.5.6 Spontaneous Generation Theory

This theory has been referred as doctrine of spontaneous generation theory /Abiogenesis (Gr. *a* = not; *bios* = life; *genesis* = origin). According to this theory all living organisms could spring forth spontaneously from nonliving matter. As far as human beings were concerned, the Greek explanation that Goddess Gaea was able to create people from stones. Men of ancient times do not know about microorganisms and evolution theory. Even astute Aristotle (384-322 BC) taught that animals might originate spontaneously from the soil, plants or other unlike animals. They believed that frogs, snakes and mice could be born of moist soil, that flies could emerge from manure and that maggots could arise from decaying corpses.

Virgil (70-19 BC) gave directions for the artificial propagation of bees.

Van Helmont (1577-1644 ) devised a method for manufacturing mice from a mixture of wheat grains with soiled linen and cheese.

Felix Archimede Pouchet (1800-1872) revived for the last time and published an extensive report proving the occurrence of spontaneous generation Fig. 1.13.

There was a great opposition against spontaneous generation theory.

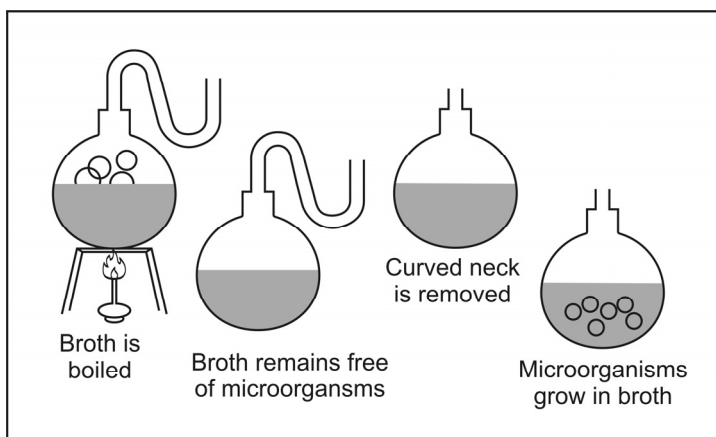

**Fig. 1.13** Pasteur's test of spontaneous generation

**Biogenesis**

This fact was lately realized that “**Only living things could beget living things.**” After the discovery of microorganisms and improvements in microscopy that enabled scientists to think seriously about original life. Francesco Redi (1626-1679) an Italian physician demonstrated by simple experiments that spontaneous generation does not exist. The following series of experiments were conducted by the scientists who supported and opposed spontaneous generation theory. Finally spontaneous generation or abiogenesis theory was proved wrong.

**First Experiment** by Redi: Rotting meat pieces were placed in jars.

Some of the jars were sealed tightly and other jars were left open

After few days both sealed and open jars were observed.

***Observation 1:*** Maggots appeared in open jars

***Reason 1:*** Flies were freely in and out and laid eggs on meat present in the open jars that resulted development of maggots.

***Observation 2:*** Maggots did not appear in sealed jars.

***Reason 2:*** Flies could not enter into sealed jars.

**Conclusion**

Maggots arise from the eggs laid down by the parent flies but not appear spontaneously.

***Criticism by the Supporters of Abiogenesis***

Free air is the vital force necessary for spontaneous origin of life. That free air was not allowed to reach the meat placed in sealed jars by Redi.

**Second Experiment** by Redi: Rotting meat pieces were placed in jars.

Jars were covered with fine muslin cloth or gauge instead of sealing them tightly.

This provision allowed free air to go in and out of the jars, few jars were left open.

**Result**

Maggots appeared only in those jars in which flies were allowed free to go in and lay their eggs on the meat.

Maggots did not appear in jars covered with fine muslin cloth.

Third Experiment by **Lazaro Spallanzani (1729-1799)**. He Boiled beef broth for an hour and then sealed flasks. No microorganisms appeared following incubation.

***Criticism by the Supporters of Abiogenesis***

John Needham insisted that air was essential to the spontaneous production of microscopic beings and it had been excluded from the flasks by sealing them in Lazzaro Spallanzani experiments.

**Fourth Experiment** by Franz Schulz (1815–1873) and Theodor Schwann (1810–1882) conducted the following experiments to give answer to John Needham's criticism

Schulz passed air through strong acid solutions and boiled infusions, whereas Schwann passed air into his flasks through red hot tubes.

***Result***

In neither case did microbes appear.

***Criticism by the Supporters of Abiogenesis***

Acid and heat altered the air so that it would not support growth.

**Fifth Experiment** by H. Schroder and T. Von Dusch (1850) performed a more convincing experiment by passing air through cotton into flasks containing heated broth.

***Result***

The microbes were filtered out of the air by the cotton fibers so that growth did not occur.

***Opposition by the Supporters of Abiogenesis***

Again Archimede Pouchet (1859) published an extensive report proving occurrence of spontaneous growth.

**Sixth Experiment** by Louis Pasteur prepared flasks with a long, narrow gooseneck opening. The nutrient solutions were heated in the flask and air, untreated and unfiltered could pass in or out. In his swan-necked flask experiments, he took various types of broths (Yeast water, Sugared yeast water, Urine sugar beet juice etc.).

***Result:*** The germs settled in the gooseneck and no microbes appeared in the solution.

***Setbacks***

Despite Pasteur's successful demonstrations against spontaneous generation, attempts to repeat his experiments occasionally failed because, after some time, existence of microbes was evident in some broths of Swan-necked flasks. This created doubt in the minds of many.

**Seventh Experiment** by John Tyndall an English physicist, in the year 1877 explained that bacteria exist in two forms. Heat labile forms (Thermo-labile) which could be killed by exposure to high temperatures and heat-resistant (Thermo-

stable) forms which could not be killed by continuous boiling of the broth and after the broth has cooled, they resulted in microbial growth in such broths. If such broths are subjected to intermittent boiling (discontinuous boiling) on successive occasions the heat-resistant forms of bacteria will be killed and the broths became completely free of them and do not show any microbial growth. This process is called as Tyndallization.

- ◆ The first boiling kills vegetative cells of bacteria but endospores remain as such.
- ◆ In cooled broth the endospores germinate into new bacteria cells which are killed during further boiling and so on.

**Eighth (Final) Experiment:** Tyndall conducted experiments in a specially developed box to prove that dust carried the germs. He demonstrated that if no dust was present sterile broth remained free of microbial growth for indefinite periods.

In this manner Tyndall validated Pasteur's results and helped ending the debate of spontaneous generation or Abiogenesis verses Biogenesis.

### Chronology of Scientists and their Contributions

Name of Scientist	Area of Research	Year
Zacharias Janssen	Invention of microscope	1590
Robert Hooke	Discovered plant cells while observing thin slices of cork in a microscope	1665
Antony Van Leeuwenhoek	Described the structure of red blood cells, protozoa and bacteria using his homemade microscope	1676
Spallanzani	Disputed the theory of spontaneous generation	1767
Edward Jenner	Introduced vaccination against smallpox	1796
M.J. Schleiden and T. Schwann	Proposed cell theory, an important landmark in biological research	1838 & 1839
Joseph Lister	Father of antiseptic surgery	1867
Louis Pasteur	Demonstrated that yeast can degrade sugar to ethanol and carbon dioxide and multiply in the process	1857
Louis Pasteur	Published experiments that refute the theory of spontaneous generation	1861
Louis Pasteur	Developed Pasteurization technique	1864
Gregor Mendel	Considered as father of genetics and published results of experiments on the laws of inheritance	1866
Koch	Demonstrated that anthrax is caused by <i>Bacillus anthracis</i>	1876 & 1877
Laveran	Discovered <i>Plasmodium</i> , that causes malaria	1880

Contd...

30 Pharmaceutical Microbiology : A Comprehensive Approach

Name of Scientist	Area of Research	Year
Koch	Discovered Cultures bacteria on gelatins, Pasteur develops anthrax vaccine	1881
Elie Metchnikoff	Discovered phagocytic cells and thus begins the study of immunology	1884
Koch	Proposed Postulates for determining the cause of a disease	1884
Christian Gram	Developed the staining techniques for identification	1884
Chamberland	Developed autoclave	1884
Louis Pasteur	Developed rabies vaccine	1885
Theodor Excherich	Identified <i>Escherichia Coli</i> as a natural inhabitant of the human gut	1885
Richard Julius Petri	Developed Petri dish	1887
Winogradsky	Studied sulphur and nitrifying bacteria	1887 – 1890
Beijerinck	Isolated root nodule bacteria	1889.
Weisman	Demonstrated the role of nucleus in heredity	1892
Paul Ehrlich	Formulated sidechain theory of antibody formation	1897
Sir Ronald Ross	Received the Nobel prize for the discovery of the lifecycle of malarial parasite in humans and mosquitoes	1902
Karl Landsteiner	Discovered blood groups	1902
Robert Koch	Received Nobel prize for founding scientific bacteriology and proving the cause of tuberculosis	1905
Wasserman	Developed complement fixation test for syphilis	1906
Paul Ehrlich	Started the use of chemotherapy to treat diseases. Receives Nobel Prize	1908
Paul Ehrlich	Synthesized a “magic bullet” for syphilis	1912
Frederick Griffith	Discovered genetic transformation in bacteria	1928
Alexander Flemming	Discovered Penicillin, the first antibiotic	1929
Karl Landsteiner	Received the Nobel prize for the discovery of the ABO human blood groups	1930
Gerhardt Komagk	Discovered sulfur drug for chemotherapy	1935
Waksman	Received Nobel prize for the discovery of streptomycin	1952
George Beadle and Edward Tatum	Produced evidence of genetic mutants	1941
Oswald Avery, Colin MacLeod and Maclyn McCarty	Demonstrated that Griffith’s transforming principle is DNA	1944

Contd...

Name of Scientist	Area of Research	Year
Alexander Fleming	Received the Nobel prize for discovering Penicillin, the first antibiotic	1945
Max Theiler	Received the Nobel prize for development of vaccine against yellow fever	1951
F.H.C Crick, J.D. Watson, M. Wilkins	Determined the structure of DNA	1953
Jonas Salk	Developed the first polio vaccine	1954
D. Bovet	Received the Nobel prize for the discovery of the first antihistamine	1957
S.Ochoa, A.Kornberg	Received Nobel Prize for the discovery of enzyme catalyzing Nucleic acid synthesis	1959
F. Jacob, J. Monod	Made discoveries about the regulation of genes	1965
Max Delbruck, Alfred Hershey and salvadore E.Luria	Received Nobel prize for describing the mechanism of viral infection of bacterial cell	1969
Hamilton Smith	Reported the discovery of the first restriction enzyme	1970
Herbert Boyer and Stanley cohen	The first Biotechnologists to clone DNA using plasmids	1973
Cesar Milsein, Georges Kohler, Niels Kai Jerne	Developed the technique for making monoclonal antibodies	1975
J.M. Bishop and H.E. Varmus	Discovered the cancer causing genes called Oncogenes	1989
R. Yalow	Received the Nobel prize for the development of the radio immuno assay technique	1977
H.D. Smith, D. Nathans, W. Arber	Received the Nobel prize for the discovery of restriction enzymes and their applications to solve the problem in molecular genetics	1978
E. Ruska	Developed the Electron Microscope	1986

## 1.6 Branches in Microbiology

Since the field of microbiology is a vast area, classification of this subject will help us to thoroughly understand this subject. The branches of microbiology can be classified into pure microbiology and applied microbiology. Microbiology can be also classified based on taxonomy, which are Bacteriology, Mycology, Protozoology and Phycology etc. But there is considerable overlap between the specific branches of microbiology with each other and with other disciplines.

### 1.6.1 Branches of Pure Microbiology

Taxonomic Arrangement of Microorganisms

- ◆ **Bacteriology:** The study of bacteria
- ◆ **Mycology:** The study of fungi
- ◆ **Protozoology:** The study of protozoa
- ◆ **Phycology (or algology):** The study of algae
- ◆ **Parasitology:** The study of parasites
- ◆ **Immunology:** The study of the immune system

#### **Integrative Arrangement of Microorganisms**

**Microbial cytology:** The study of microscopic and submicroscopic details of microorganisms.

**Microbial physiology:** The study of how the microbial cell functions biochemically. It includes the study of microbial growth, microbial metabolism and microbial cell structure.

**Microbial ecology:** The relationship between microorganisms and their environment.

**Microbial genetics:** The study of how genes are organized and regulated in microbes in relation to their cellular functions. It is closely related to the field of molecular biology.

**Cellular microbiology:** A discipline bridging microbiology and cell biology.

**Evolutionary microbiology:** The study of the evolution of microbes. This field can be subdivided into:

**Microbial taxonomy:** The naming and classification of microorganisms.

**Microbial systematic:** The study of the diversity and genetic relationship of microorganisms.

**Generation microbiology:** The study of those microorganisms that have the same characters as their parents.

#### **Other Arrangement of Microorganisms**

**Nano microbiology:** The study of those microorganisms at nano level.

**Exo microbiology (or Astro microbiology):** The study of microorganisms in outer space.

### 1.6.2 Branches of Applied Microbiology

**Medical Microbiology:** The study of the pathogenic microbes and the role of microbes in human illness include the study of microbial pathogenesis and epidemiology and is related to the study of disease pathology and immunology.



**Pharmaceutical Microbiology:** The study of microorganisms that are related to the production of antibiotics, enzymes, vitamins, vaccines, and other pharmaceutical products and that cause pharmaceutical contamination and spoil.

**Industrial Microbiology:** The exploitation of microbes for use in industrial processes. Examples include industrial fermentation and wastewater treatment. This branch is closely linked to the biotechnology industry. This field also includes brewing, an important application of microbiology.

**Microbial Biotechnology:** The manipulation of microorganisms at the genetic and molecular level to generate useful products.

**Food Microbiology and Dairy Microbiology:** The study of microorganisms causing food spoilage and food borne illness. It also includes using microorganisms to produce foods, for example by fermentation.

**Agricultural Microbiology:** The study of agriculturally relevant microorganisms. This field can be further classified into the following:

**Plant microbiology and Plant pathology:** The study of the interactions between microorganisms and plants and plant pathogens.

**Soil microbiology:** The study of those microorganisms that are found in soil.

**Veterinary microbiology:** The study of the role in microbes in veterinary medicine or animal taxonomy.

**Environmental microbiology:** The study of the function and diversity of microbes in their natural environments. This involves the characterization of key bacterial habitats such as the rhizosphere and phyllosphere, soil and groundwater ecosystems, open oceans or extreme environments (extremophiles). This field includes other branches of microbiology such as:

- (a) Microbial Ecology
- (b) Microbial-mediated Nutrient Cycling
- (c) Geomicrobiology
- (d) Microbial Diversity
- (e) Bioremediation

**Water microbiology (or Aquatic microbiology):** The study of those microorganisms that are found in water.

**Aeromicrobiology (or Air microbiology):** The study of airborne microorganisms.

**Epidemiology:** The study of the incidence spread and control of disease.

### Essay Questions

1. Explain in detail the detailed structure of microorganisms.
2. Write a note on initial microscopes and their constructions along with a simplified ray diagrams.
3. Explain the developments and discoveries of scientists in microbiology.

### Multiple Choice Questions

1. Spontaneous generation theory is also known as
  - (a) Biogenesis
  - (b) Abiogenesis
  - (c) Neobiogenesis
  - (d) Microbiogenesis
2. Bright field microscope provides magnification of about
  - (a) 1000x to 1200x
  - (b) 500x to 1000x
  - (c) 2000x to 4000x
  - (d) 5000x to 10000x
3. Main disadvantage of Scanning Electron Microscope is
  - (a) Lacking projection power
  - (b) Lacking focal power
  - (c) Lacking resolving power
  - (d) Lacking diffracting power
4. Scientist who made more than 500 microscopes
  - (a) Max Theiler
  - (b) Frederick grifth
  - (c) Leeuwenhoek
  - (d) Robert Koch
5. Fleming was investigating the properties
  - (a) Staphylococci
  - (b) Anthrax bacilli
  - (c) Listeria monocytogenes
  - (d) Eschereschia coli
6. Manipulation of microorganisms at genetic and molecular level to generate useful products is known as
  - (a) Pharmaceutical Microbiology
  - (b) Industrial Microbiology
  - (c) Microbial biotechnology
  - (d) Food microbiology & Diary microbiology
7. The study of incidence, spread and control of disease is called as
  - (a) Geo microbiology
  - (b) Microbial diversity
  - (c) Epidemiology
  - (d) Bioremediation

### Answers

- |        |        |        |
|--------|--------|--------|
| 1. (b) | 2. (a) | 3. (c) |
| 4. (c) | 5. (a) | 6. (c) |
| 7. (c) |        |        |